

SP4P1-B4

7/8-14 UNF • Q_{max} 40 l/min (11 GPM) • p_{max} 30 bar (435 PSI)

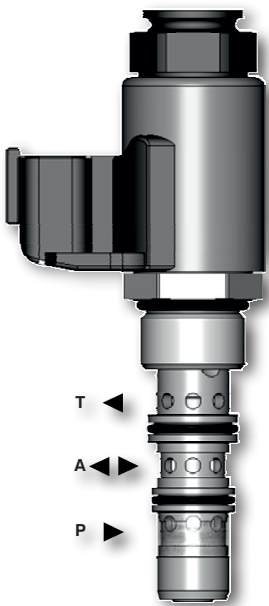

Technical Features

- › Excellent stability throughout flow range with rapid response to proportional current input change
- › Low hysteresis, accurate pressure control and low pressure drop through CFD optimized flow paths
- › Precise pressure control vs current and excellent repeatability
- › Integrated relief function for protection against pressure peaks
- › Solenoid electrical terminal: AMP Junior Timer or Deutsch DT04-2P
- › 12 or 24 V DC coils
- › Compact design with reduced solenoid dimensions for production cost saving
- › High flow capacity and low coil power consumption
- › Optional mesh screen
- › In the standard version, the valve is zinc-coated for 240 h protection acc. to ISO 9227

Functional Description

A pilot-operated, spool-type hydraulic pressure reducing valve in the form of a screw-in cartridge. Reduced pressure output is proportional to DC current input. This valve is intended for use as a pressure limiting device. Note: Consult factory for special OEM versions of this product.

Model Code	no mesh screen	with mesh screen
Symbol		



For B4 cavity (C-10-4)

The front channel **cannot be** used due to high pressure loss.

Technical Data

Valve size / Cartridge cavity		7/8-14 UNF-2A / B4 (C-10-4)	
Max. operating pressure (port P)	bar (PSI)	30 (435)	
Max. reducing pressure (port A)	bar (PSI)	25 (363)	
Max. flow rate P-A	l/min (GPM)	40 (11)	
Max. control flow	l/min (GPM)	0.4 (0.12)	
Fluid temperature range (NBR)	°C (°F)	-30 ...90 (-22 ...194), +100 (212) short time	
Fluid temperature range (FPM)	°C (°F)	-20 ...90 (-4 ...194), +100 (212) short time	
Ambient temperature range	°C (°F)	-30 ...90 (-22 ...194), +100 (212) short time	
Response time at 100 % signal	ms	< 50	
Solenoid data			
Supply voltage	V	12 DC	24 DC
Max. current	A	0.7	0.35
Rated resistance at 20 °C (68 °F)	Ω	7.82±5 %	29.5±4.5 %
Duty cycle	%	100	
Optimal PWM frequency	Hz	200	
Quenching diode		BZW06-28B	BZW06-33B
Enclosure type acc.to EN 60529**		(acc.to terminal type) IP67 / IP69K	
Weight with solenoid	kg (lbs)	0.3 (0.66)	
General information		Data Sheet	Type
		GI_0060	Products and operating conditions
Coil types		C_8007	
Valve bodies	In-line mounted	SB_0018	SB-B4*
	Sandwich mounted	SB-04(06)_0028	SB-*B4*
Cavity details / Form tools		SMT_0019	SMT-B4*
Spare parts		SP_8010	



The volume flow, which is needed for control of output pressure and maintaining the adjusted value of reducing pressure, flows permanently through the pilot stage of valve.

**The indicated IP protection level is only reached with a properly mounted connector.

Characteristics measured at $v = 32 \text{ mm}^2/\text{s}$ (156 SUS)

Reduced pressure related to control signal

Port A of range 0 - 25 bar (363 PSI), $Q = 0 \text{ lpm}$ (GPM)
 Port P inlet pressure 30 bar (435 PSI)
 measured without mesh screen

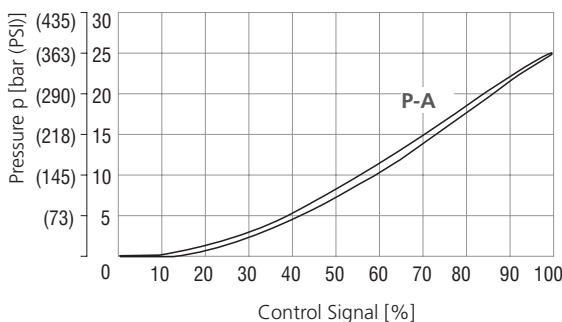

Pressure drop related to flow rate

— A-T Valve coil de-energized (relieving function)
 — P-A Valve coil energized (reducing function)
 measured without mesh screen

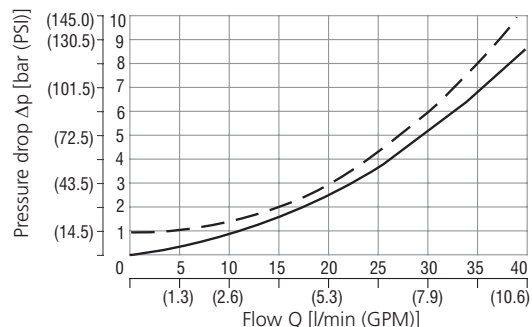

Characteristics measured at $v = 32 \text{ mm}^2/\text{s}$ (156 SUS)

Reducing - relieving pressure related to flow rate

Reducing pressure range 0 - 25 bar (0 - 363 PSI), input 30 bar (435 PSI)
 various control currents
 measured without mesh screen

relieving function A-T / reducing function P-A

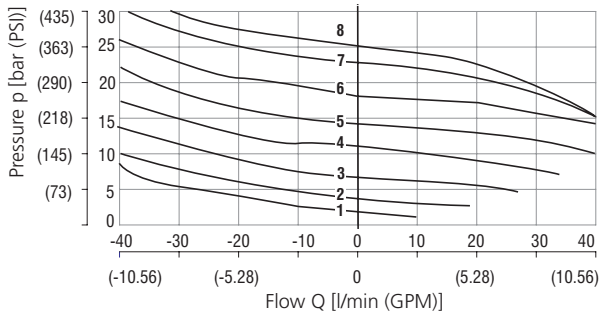

1	2	3	4	5	6	7	8
24%	35%	47%	59%	70%	82%	94%	100%

Frequency response characteristics

Inlet pressure at port P - 30 bar (435 PSI), flow = 0 lpm (GPM)

----- signal $70 \pm 25\%$
 ——— signal $55 \pm 40\%$

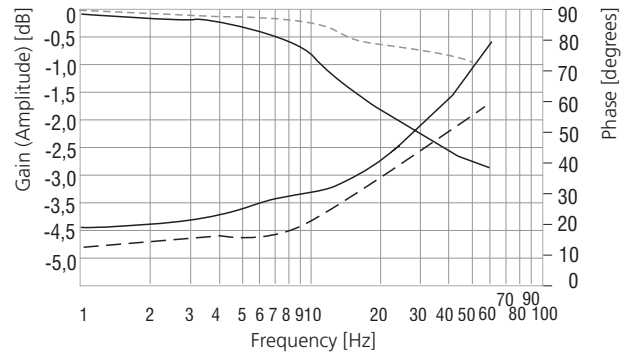

Dimensions in millimeters (inches)

Connector type

E3A, E4A - IP67
 AMP Junior Timer

E12A, E13A - IP67 / IP69K
 Deutsch DT04-2P

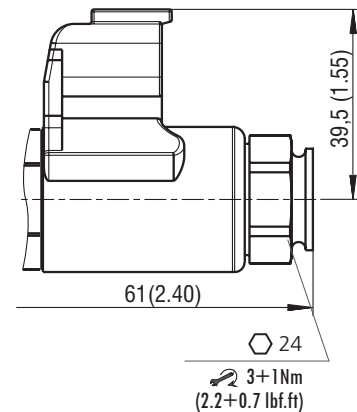
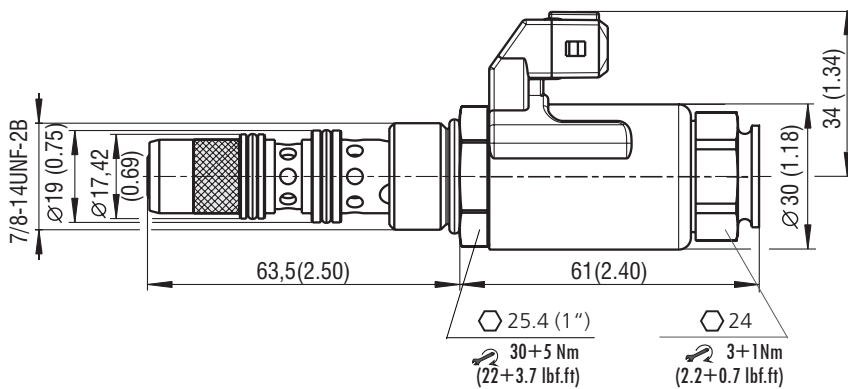

Ordering Code

SP4P1-B4 / - -

Proportional pressure control valve,
 reducing - relieving, pilot operated,
 screw-in style

Valve cavity
 7/8-14 UNF (C-10-4)

Max. reducing pressure
 20 bar (290 PSI) **20**
 25 bar (363 PSI) **25**

Supply voltage / max. current
 12 V DC / 0.7 A **12**
 24 V DC / 0.35 A **24**

No designation
 SP-300

Mesh screen
 without mesh screen
 port P, 300 microns

A Surface treatment
 zinc-coated (ZnCr-3), ISO 9227 (240 h)
 B zinc-coated (ZnNi), ISO 9227 (520 h)

No designation
 V

Seals
 NBR
 FPM (Viton)

E3A AMP Junior Timer - axial direction (2 pins; male)
 E4A E3A with quenching diode
 E12A Deutsch DT04-2P - axial direction
 E13A E12A with quenching diode